

HYDRAULICALLY-POWERED

**BOX & PAN BRAKES
LEAF BRAKES**



VIRLI



Hydraulically-Powered Box & Pan Brakes and Leaf Brakes

VIRLI Hydraulically-Powered Box & Pan Brakes and Leaf Brakes provide a wide choice of sizes and capacities to suit individual needs and budgets. These machines can be the ideal choice for companies that need bending capabilities but do not need or cannot afford or justify a high-cost folding machine or press brake.

The range includes Box & Pan Models "H" with hydraulic bending and manual clamping (for the lowest possible prices), Models "FH" with hydraulic bending and hydraulic clamping and Models "FHRA" with hydraulic clamping, hydraulic bending and rapid adjustment for material thickness, all as further described in the table below.

Throughout the range, heavy plate construction and proven designs provide accurate bending over the long life of each machine. Apron, bed, head-sides and hydraulic-ram mountings have been designed for minimum deflection under load. As a result of the superior design, the full tonnage delivered by clamping rams is transferred to the head through the trunnion bearings mounted to the side frames. This centers the load evenly on the sides. The load is then transferred to the fingers which are solid one-piece segments of high grade carbon steel allowing the full load of the material being bent to be spread over an equal area of the head. This achieves a smaller radius and a straighter edge. A mechanical bend-angle control is standard equipment on H and FH Models. The FHRA Models are equipped as standard with a 10-bend electronic control for programming ten bend-angles and ten open heights and for storing up to 99 different jobs.

The Hydraulically-Powered Leaf Brakes provide comparable bending capacities and design and construction for those companies that do not foresee the need for box and pan bending, thus resulting in somewhat lower prices.

These options are available to enhance the already efficient and effective operation of the machines:

- A 10-bend electronic control for programming 10 bend-angles and 10 open heights.
Stores up to 99 different jobs.
- Electronic 10-Position Backgauge Control to work with the 10-Bend Control.
Range 24" or 38". Operates on ballscrews. Includes sheet metal support.
- One-piece nose bar, allowing a box and pan to be operated as a power leaf brake.
- Set of fingers, allowing a leaf brake to be operated as a box and pan brake.

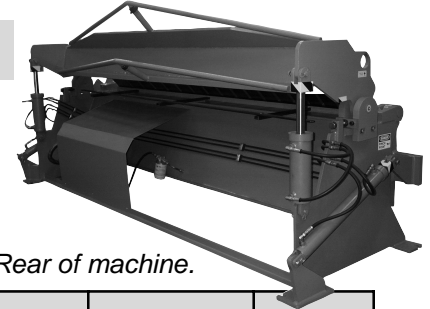

Rear of machine.

MODEL	CAPACITY MILD STEEL	BACK GAUGE RANGE	LENGTH OF FINGERS	MAXIMUM BOX HEIGHT	MINIMUM FLANGE For Maximum Material	RADIUS OF FINGERS	MOTOR HP	DIMENSIONS L x F-B x H INCHES	WEIGHT LBS.
BOX AND PAN MODELS									
H-4-14	4' x 14 ga.	18"	10"	3-3/4"	1"	1/32"	5	98 x 55 x 59	2150
H-6-14	6' x 14 ga.	18"	10"	3-3/4"	1"	1/32"	5	112 x 55 x 59	2250
H-8-14	8' x 14 ga.	18"	10"	3-3/4"	1"	1/32"	5	137 x 55 x 59	3700
H-10-14	10' x 14 ga.	18"	10"	3-3/4"	1-1/4"	1/32"	5	165 x 55 x 59	4000
H-12-14	12' x 14 ga.	18"	10"	3-3/4"	1-1/4"	1/32"	5	190 x 55 x 59	5500
LEAF BRAKE MODELS									
FH-4-14	4' x 14 ga.	18"	10"	3-3/4"	1"	1/32"	5	98 x 55 x 59	2300
FH-6-14	6' x 14 ga.	18"	10"	3-3/4"	1"	1/32"	5	112 x 55 x 59	2500
FH-8-14	8' x 14 ga.	18"	10"	3-3/4"	1"	1/32"	5	137 x 55 x 59	3900
FH-10-14	10' x 14 ga.	18"	10"	3-3/4"	1"	1/32"	7-1/2	165 x 55 x 59	4400
FH 12-14	12' x 14 ga.	18"	10"	3-3/4"	1-1/4"	1/32"	7-1/2	190 x 55 x 59	6000
FH-4-10	4' x 10 ga.	18"	13-3/4"	5"	1"	3/64"	7-1/2	100 x 55 x 59	4000
FH-6-10	6' x 10 ga.	18"	13-3/4"	5"	1"	3/64"	7-1/2	113 x 55 x 59	5500
FH-8-10	8' x 10 ga.	18"	13-3/4"	5"	1"	3/64"	7-1/2	138 x 55 x 59	7100
FH-10-10	10' x 10 ga.	18"	13-3/4"	5"	1-1/4"	3/64"	7-1/2	166 x 55 x 67	8800
FH-12-10	12' x 10 ga.	18"	13-3/4"	5"	1-1/4"	3/64"	7-1/2	191 x 55 x 69	11400
FHRA-8-250	8' x 1/4"	18"	13-3/4"	5"	2"	1/16"	10	138 x 55 x 67	9500
FHRA-10-250	10' x 1/4"	18"	13-3/4"	5"	2"	1/16"	10	170 x 55 x 67	11000
FHRA-12-250	12' x 1/4"	18"	13-3/4"	5"	2"	1/16"	10	195 x 55 x 74	13700
LEAF BRAKE MODELS									
F-8-14-LB	8' x 14 ga.	18"	-	-	1"	-	5	137 x 55 x 59	3200
F-8-10-LB	8' x 10 ga.	18"	-	-	1"	-	7-1/2	138 x 55 x 59	6800
F-10-14-LB	10' x 14 ga.	18"	-	-	1"	-	5	165 x 55 x 59	4000
F-10-10-LB	10' x 10 ga.	18"	-	-	1-1/4"	-	7-1/2	165 x 55 x 67	8800
FH-8-14-LB	8' x 14 ga.	18"	-	-	1"	-	5	137 x 55 x 59	3900

All specifications and data are approximate and subject to correction/change without prior notice.

EXCLUSIVE NORTH AMERICAN DISTRIBUTOR:

COLE-TUVE, INC.

Box 233, White Marsh, Maryland 21162-0233

Phone: (410) 933-0700 Fax: (410) 933-0600

Internet: www.coletuve.com E-mail: info@coletuve.com

© COLE-TUVE, Inc. 2002

YOUR AUTHORIZED DISTRIBUTOR: